

Dynamic Capabilities of Capacity on Demand

Sanjiv Patel
rp8400 Product Manager
Hewlett-Packard Company

Agenda

- What is capacity on demand?
- Capacity on demand customer profile
- How it works
- Email requirements
- Capacity on demand benefits
- What's next?

What is capacity on demand?

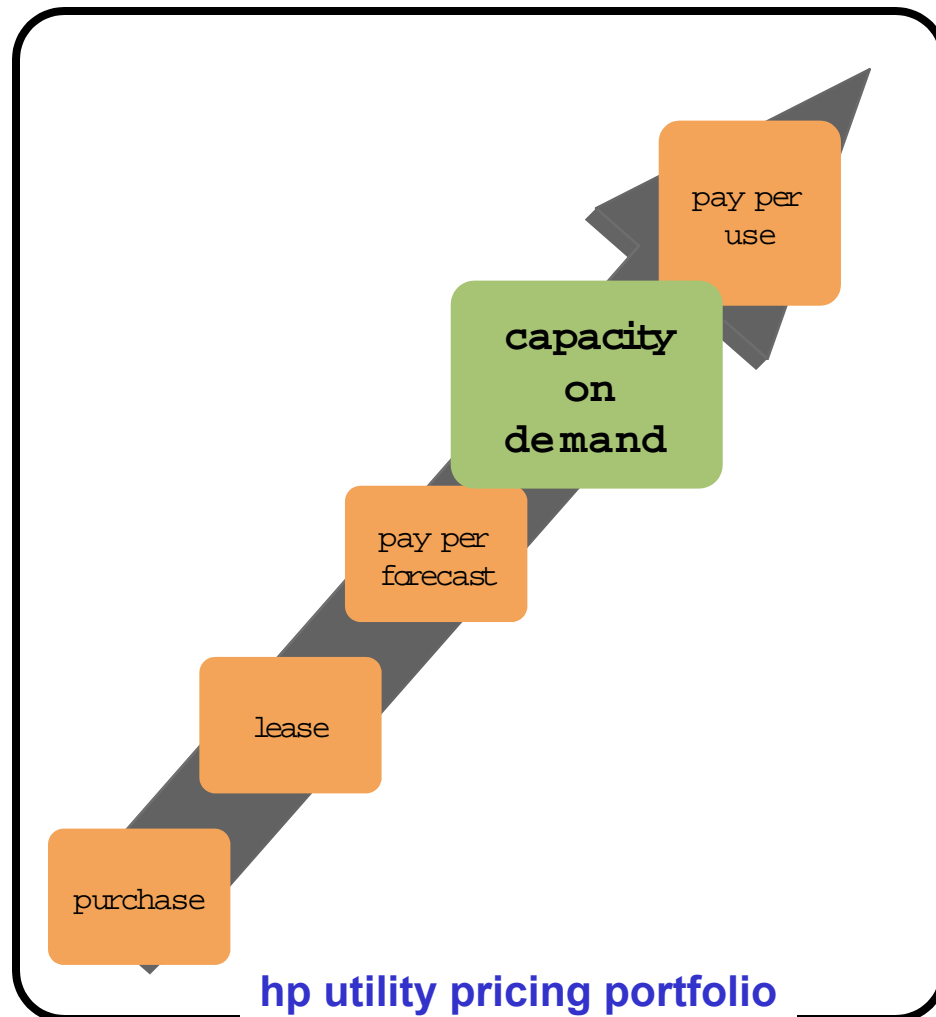

Instant capacity on demand

Temporary capacity
on demand

Cell capacity on demand

- Introduced for HP systems since early 2002
 - Over 6,500 iCOD CPUs shipped
- Available for rp54xx, rp7400, rp7410, rp8400, V-Class, and Superdome servers

Capacity on demand customer profile

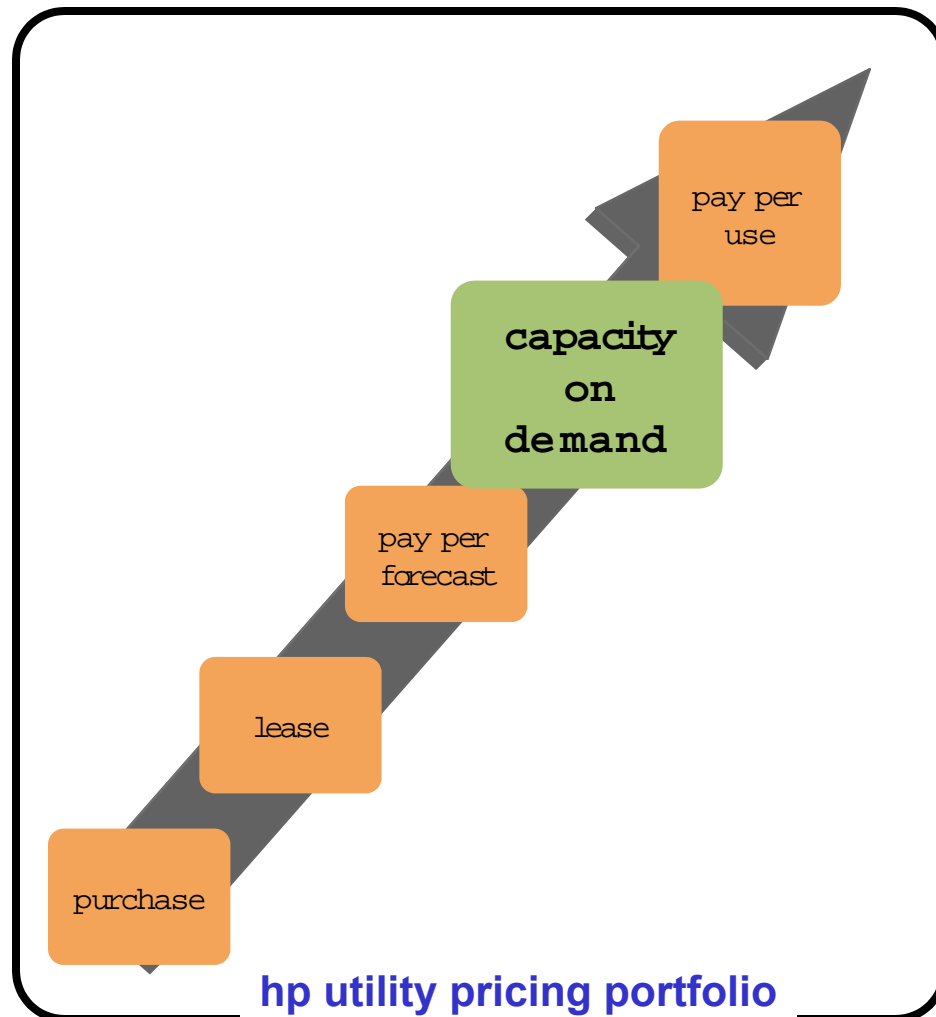

Instant capacity on demand

Temporary capacity on demand

Cell capacity on demand

- High and growing demand
 - ✓ Planned future growth
 - ✓ Growth is unpredictable
- Preference or requirement for infrastructure expenses:
 - ✓ capital vs expense model

How it works

General requirements:

- Purchase iCOD “right to access” CPUs
- Receive iCOD processor agent license
- Factory or field installed
- email connectivity with hp

Inactive processors reside in system

- does not require additional hp support or hp software licensing until activation

CPU purchase – “activation” fee

- current CPU list price (less volume agreement)

Activation with license key

- Received from hp via email

Instant capacity on demand

Temporary capacity
on demand

Cell capacity on demand

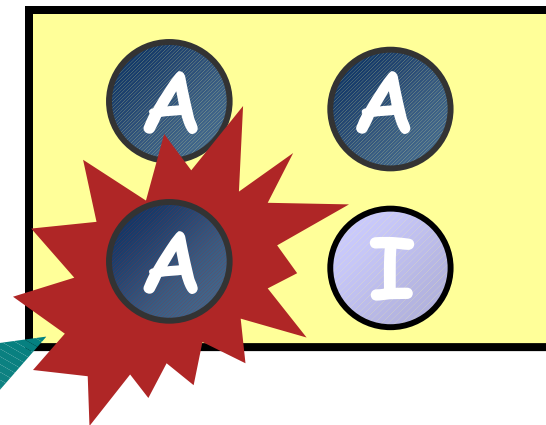

How it works

General requirements:

- Purchase iCOD “right to access” CPUs
- Receive iCOD processor agent license
- Purchase temporary capacity 30-day license (720 hours) for system
 - includes temporary license for HP-UX and support
- email connectivity with hp

Processor(s) may be activated and deactivated

- processor usage deducted from 720 hour total
- balance can be tracked on web portal

Additional license may be purchased after 720 hours usage

Instant capacity on demand

Temporary capacity
on demand

Cell capacity on demand

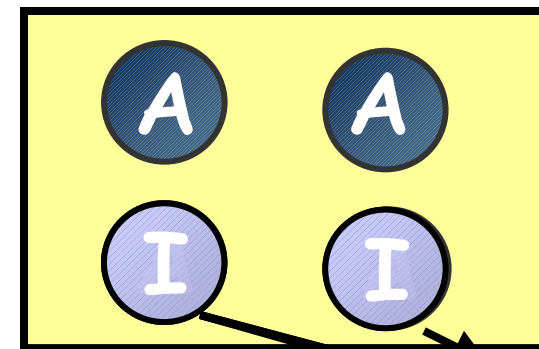

Capacity (hours): **700**

Instant capacity on demand

Temporary capacity on demand

Cell capacity on demand

HP Pay Per Use - Microsoft Internet Explorer provided by Hewlett-Packard

Address: <http://voila.rsn.hp.com:8082/cgi-bin/ppu.cgi>

usage for DEH4144020 on 09/04/2001

partition	from	to	elapsed seconds	active cpus	total cpus	method ¹	
0	00:00:00	12:00:00	43,200	32.000	32.000	ACTUAL	→ more ...
0	12:00:01	23:59:59	43,200	32.000	32.000	ACTUAL	→ more ...
1	00:00:00	08:00:00	28,800	32.000	32.000	ACTUAL	→ more ...
1	08:00:01	09:00:00	3,600	32.000	32.000	ACTUAL	→ more ...
1	09:00:01	10:00:00	3,600	0.000	32.000	IDLE	→ more ...
1	10:00:01	23:59:59	50,400	20.000	32.000	ACTUAL	→ more ...

daily usage summary

Active CPU Seconds	4,809,600.000
Total CPU Seconds	5,529,600.000
Complex Usage ² (%)	86.979

Note: 4,809,600.000 / 5,529,600.000 * 100 -> 86.979

How it works

General requirements:

- Purchase iCOD “right to access” cell board:
 - CPUs
 - memory
- Receive iCOD processor agent license
- email connectivity with hp

Inactive cell board resides in system

- not considered from software licensing or support pricing perspective

Cell board purchase – “right to use” fee

- current list prices (less volume agreement)

Activation with license key

- Received from hp via email
- Cell boot required

Instant capacity on demand

Temporary capacity on demand

Cell capacity on demand

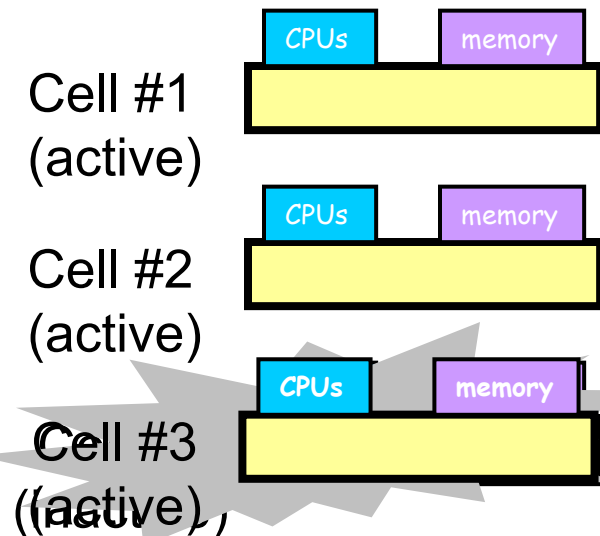

Email requirements

iCOD system must be network-accessible to mail servers that are outside company firewalls

- Allows hp audit system to track disposition of capacity on demand processors

Email chosen because of its wide applicability to broad scope of companies and ability to send encrypted data

Only the ability to send mail is required

Instant capacity on demand

Temporary capacity
on demand

Cell capacity on demand

Capacity on Demand benefits

Instant processing power with a single command

High Availability benefit in the event of processor failure

Lower costs and increased flexibility

Capability to load balance partitions with no additional cost

Instant capacity on demand

Temporary capacity on demand

Cell capacity on demand

Instant processing power with a single command

Activation takes microseconds

No reboot required for iCOD and temporary capacity on demand

- Zero downtime to increase processing power

High Availability benefit in the event of processor failure

iCOD processors may be used as automatic “hot-spares” in the event of an LPMC:

- Failing active CPU deallocated
- iCOD processor activated instantly
- No interruption to workload
- No additional cost

In event of HPMC which requires a reboot, iCOD processor can replace failed processor

Lower costs and increased flexibility

Instant capacity on demand

- Upfront right to access fee
- CPU list price at time of activation (“iCOD enablement”)

Temporary capacity on demand

- Upfront right to access fee
- Upfront temporary capacity on demand 30-day license

Cell capacity on demand

iCOD Right to Access (per CPU)

Product	Price
Superdome	\$4,000
rp8400	\$3,000
rp7410	\$3,000
rp54xx	\$2,000

Temporary Capacity on Demand

Product	Price
Superdome	\$3,400
rp8400	\$2,800
rp7410	\$2,800
rp54xx	\$1,500

Lower costs and increased flexibility

Example

750 MHz CPU pricing, rp8400
(Sept 2001-Sept 2002)

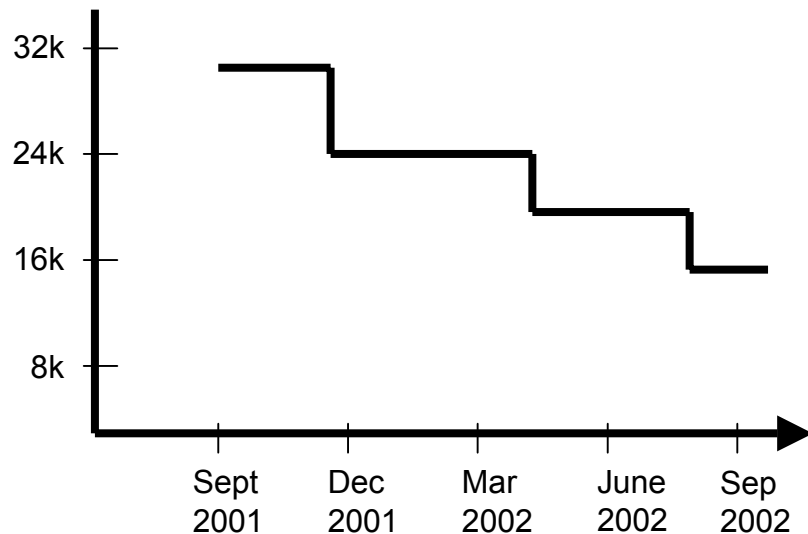

hp server rp8400 purchased (Sep 2001)

Eight processors required today;
2 processors expected in
approximately 6 months:

1. Upfront CPU purchase (total 10 CPUs)
2. iCOD purchase with activation in ~ 6 months

Lower costs and increased flexibility

Processor capacity on demand

	Upfront CPU purchase	Processor iCOD
CPU acquisition cost	\$58,000	\$6,000
iCOD acquisition cost	\$0	\$46,000
Total CPU cost	\$58,000	\$52,000
Support costs (2 CPUs, 6 months 24x7 contract)	\$\$\$\$	\$0
Software licensing (2 CPUs, 6 months)	\$\$\$\$	\$0
Total 6-month cost	\$58,000++	\$52,000

Lower costs and increased flexibility

Temporary capacity on demand

Assumption: Two CPUs used for three days per month

30-day license lasts for 5 months

- 2 CPUs X 3 days per month X 5 months = 30 days usage

	Upfront CPU purchase	Temporary capacity
CPU acquisition cost	\$58,000	\$8,800
iCOD acquisition cost	\$0	\$46,000
Total CPU cost	\$58,000	\$54,800
Support costs (2 CPUs, 6 months 24x7 contract)	\$\$\$\$	\$0
Software licensing (2 CPUs, 6 months)	\$\$\$\$	\$0
Total 6-month cost	\$58,000++	\$54,800

Capability to load balance partitions with no additional cost

- Capacity on demand offers increased flexibility with cell-based systems:
 - rp7410 (8-way)
 - rp8400 (16-way)
 - Superdome (32/64-way)
- Capacity on demand iCOD processors compatible with hard partitions and virtual partitions (vPars)

Capability to load balance partitions with no additional cost

With standard processor iCOD:

Partition 1

Applications A & B:

- Increased performance required

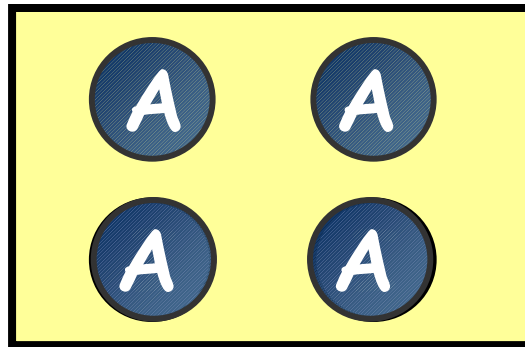

Partition 2

Applications C & D:

- Excess capacity

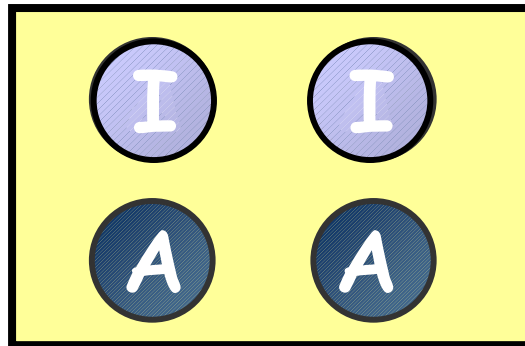

Capability to load balance partitions with no additional cost

With temporary capacity on demand:

Partition 1

Applications A & B:

- Increased performance required

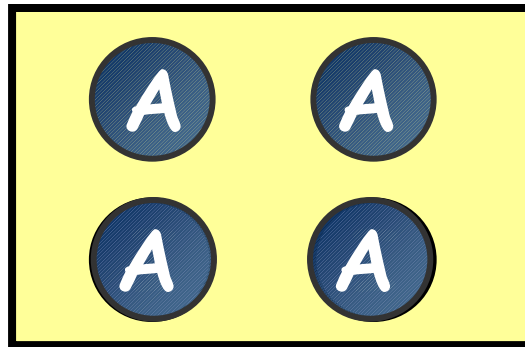

Partition 2

Applications C & D:

- Excess capacity

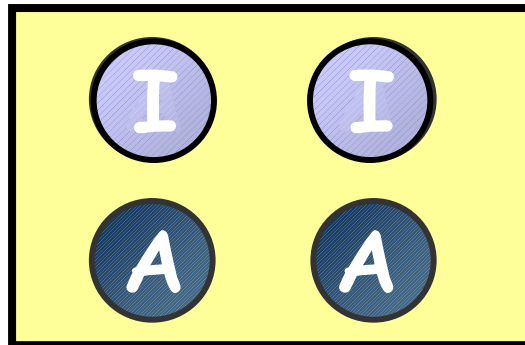

Capability to load balance partitions with no additional cost

With cell capacity on demand (example 1):

Partition 1

Applications A & B:

- Increased performance required

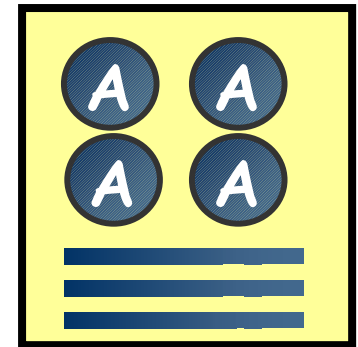
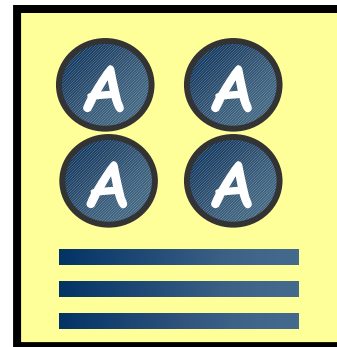
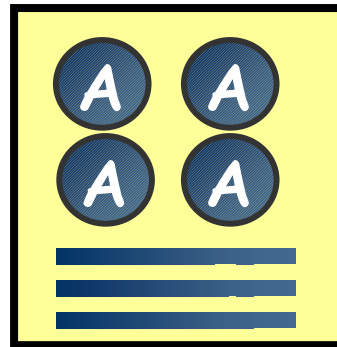

Partition 2

Applications C & D:

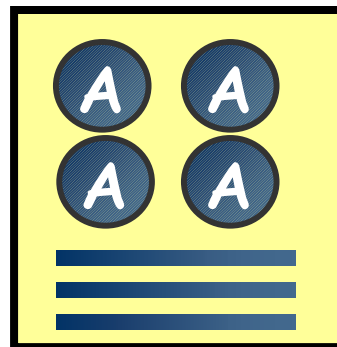

Capability to load balance partitions with no additional cost

With cell capacity on demand (example 2):

Partition 1

Applications A & B:

- Excess capacity

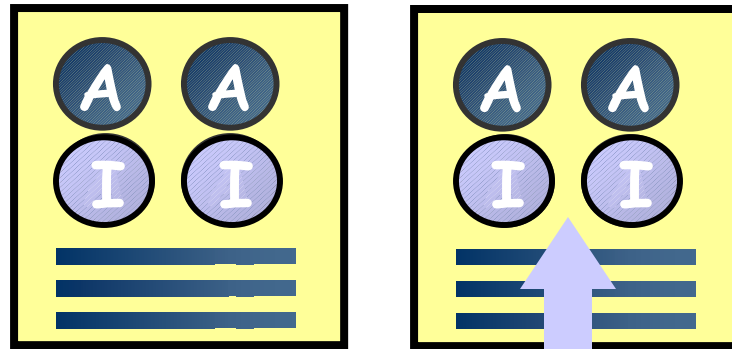

Partition 2

Applications C & D:

- Increased performance required

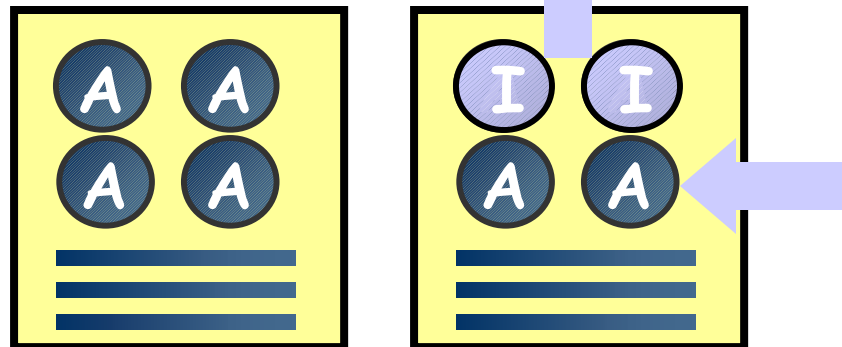

What's next?

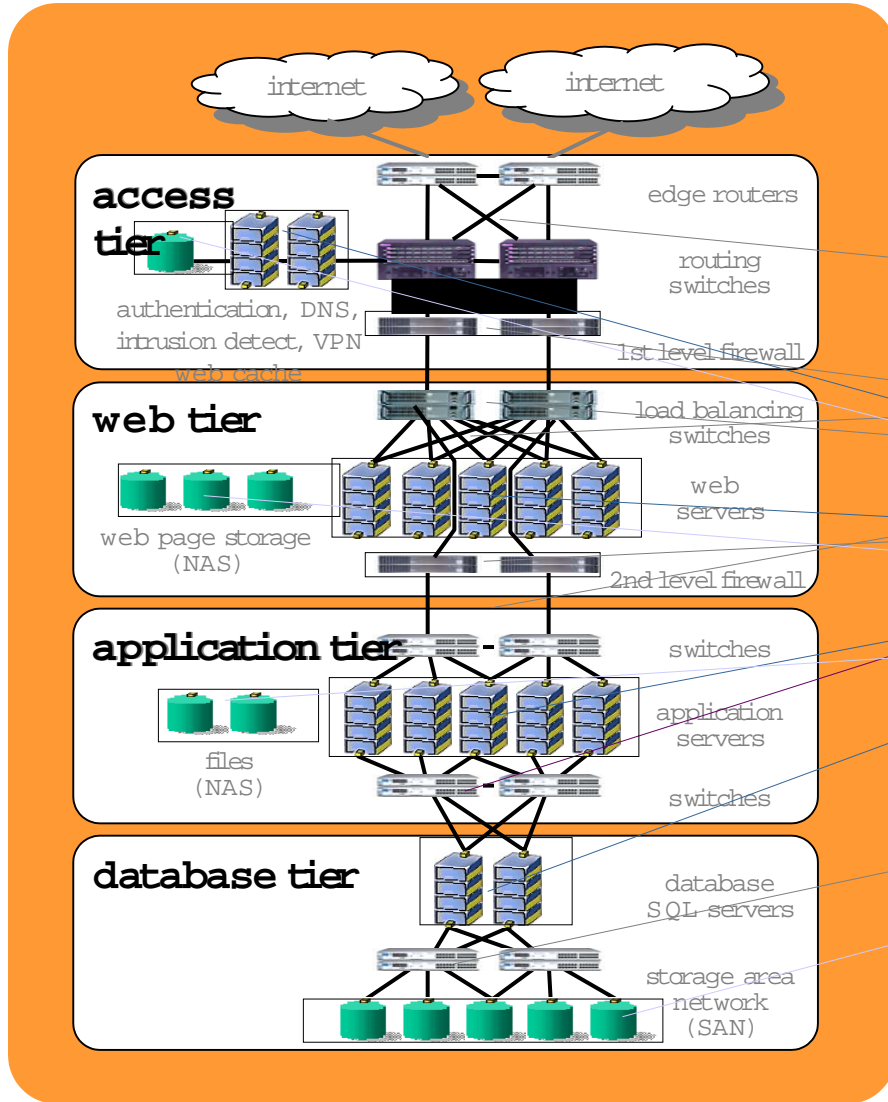

hp utility data center
transform your data center using
existing assets

