

***Global Enterprise
Integration
Collaboration Solutions
@ work***

Ray Mooney

CTO Integration Technologies & Services
Solutia Inc.



Today's Topics

Overview of Integration Landscape

Strategy & Challenges

Collaboration Framework

Benefits & Value

Key Learnings

I. Integration Landscape & Solutia Overview

Business Diversity



RESINS AND ADDITIVES



Global Operations

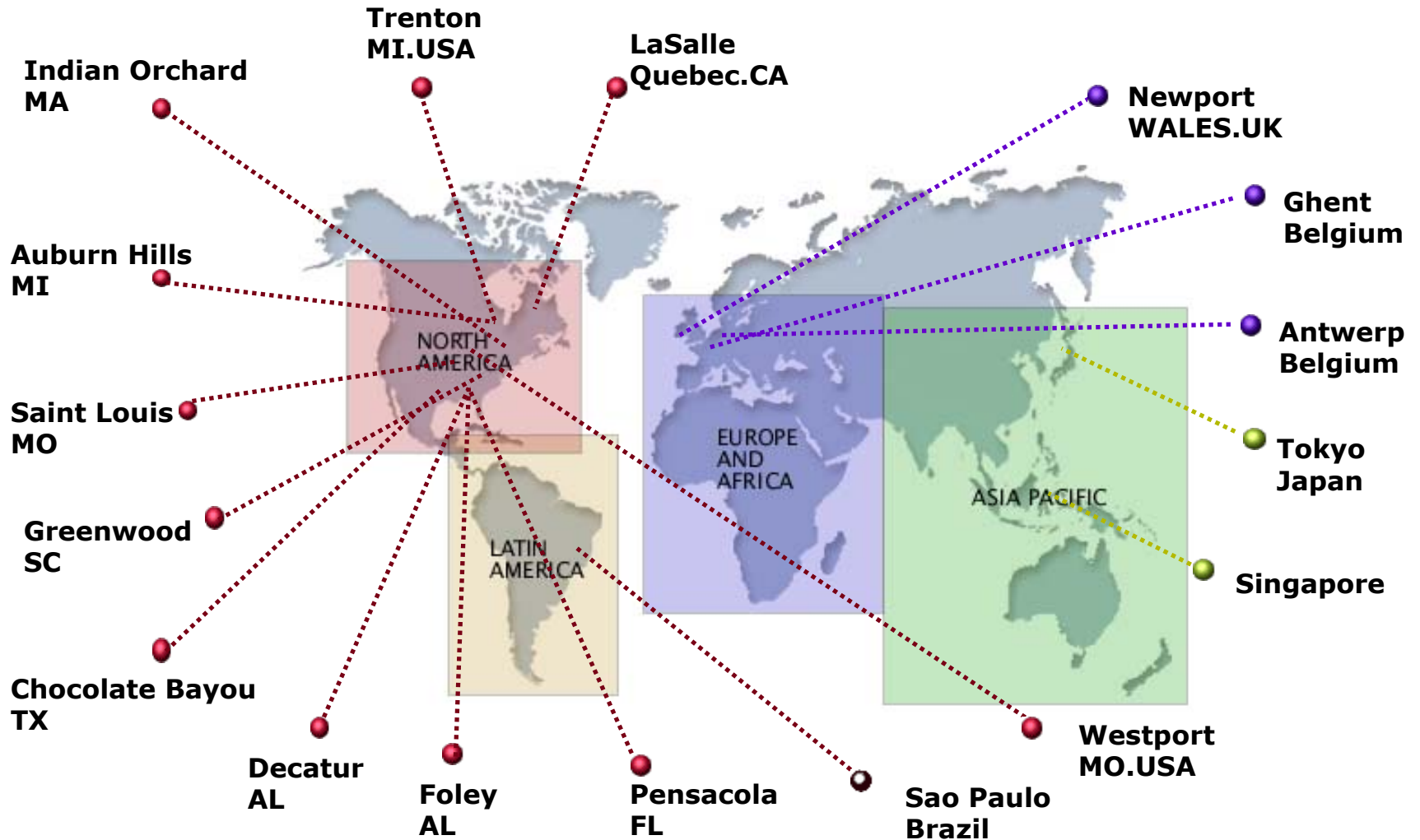

II. Strategies & Challenges

.... All business processes will be able to integrate **internally and **with partners**....**

.... Deployment will be **rapid & seamless across plant and partner locations regardless of technology platforms**

.... The implemented environment will be **flexible, scaleable and easy to maintain & support**

Enterprise Integration Strategy

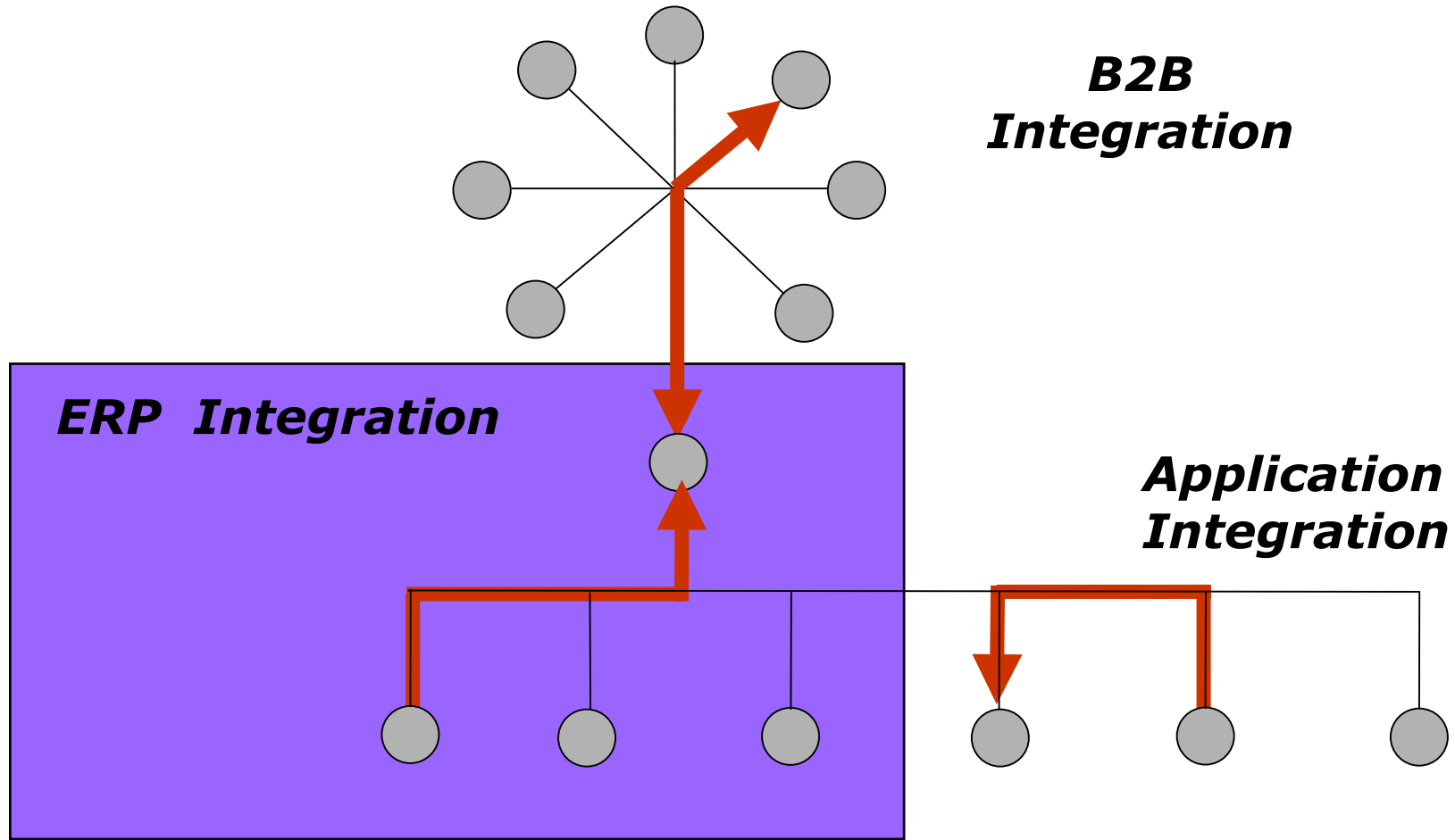

Step 1 : SAP – ERP Challenge

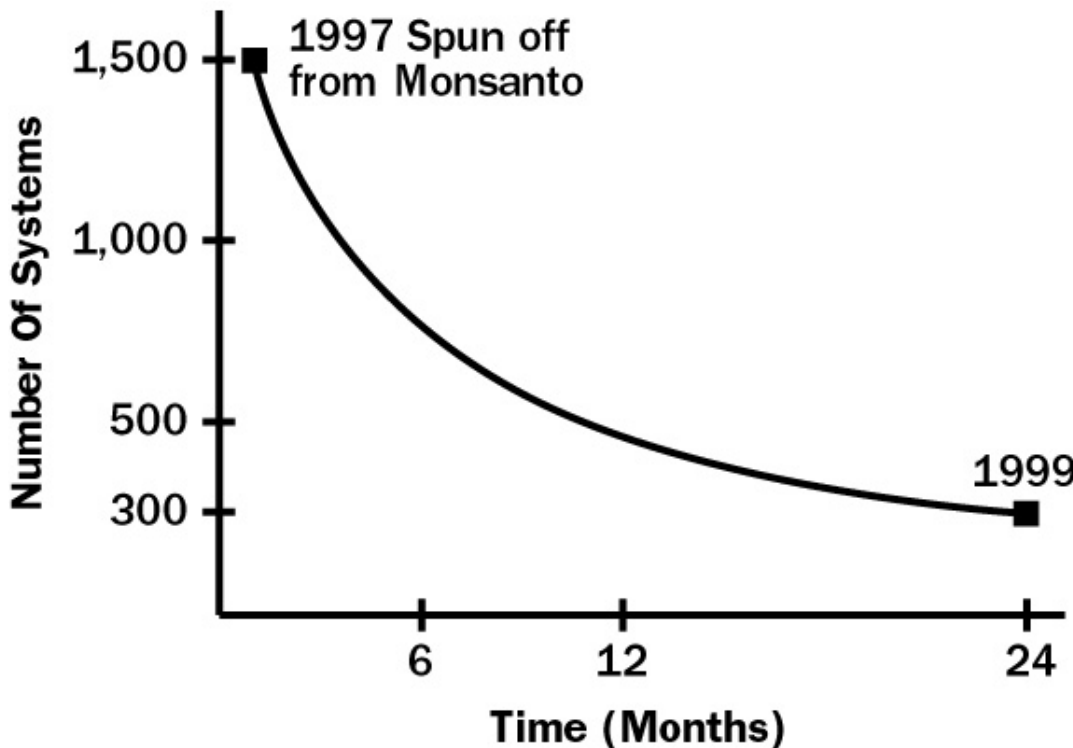

SAP Replaced + 1,200 Legacy Applications, but 300 “Best Practice” Applications Were Retained

SAP – ERP Scope

- **SAP ERP 4.6 - Single Global Instance**
- **All Global Business Processes**
 - Plant Application Integration ... 20+ Plants, 24 x 7
 - MES: Manufacturing Execution Systems
 - Sales & Distribution, Inventory, Warehouse Management
 - Barcode, Radio Frequency, Scales, LIMS
- **Architectures & Framework**
 - All Platforms: DEC, HP, IBM, Intel
- **Systems**
 - Custom and Purchased, Old and New

Enterprise Integration Strategy

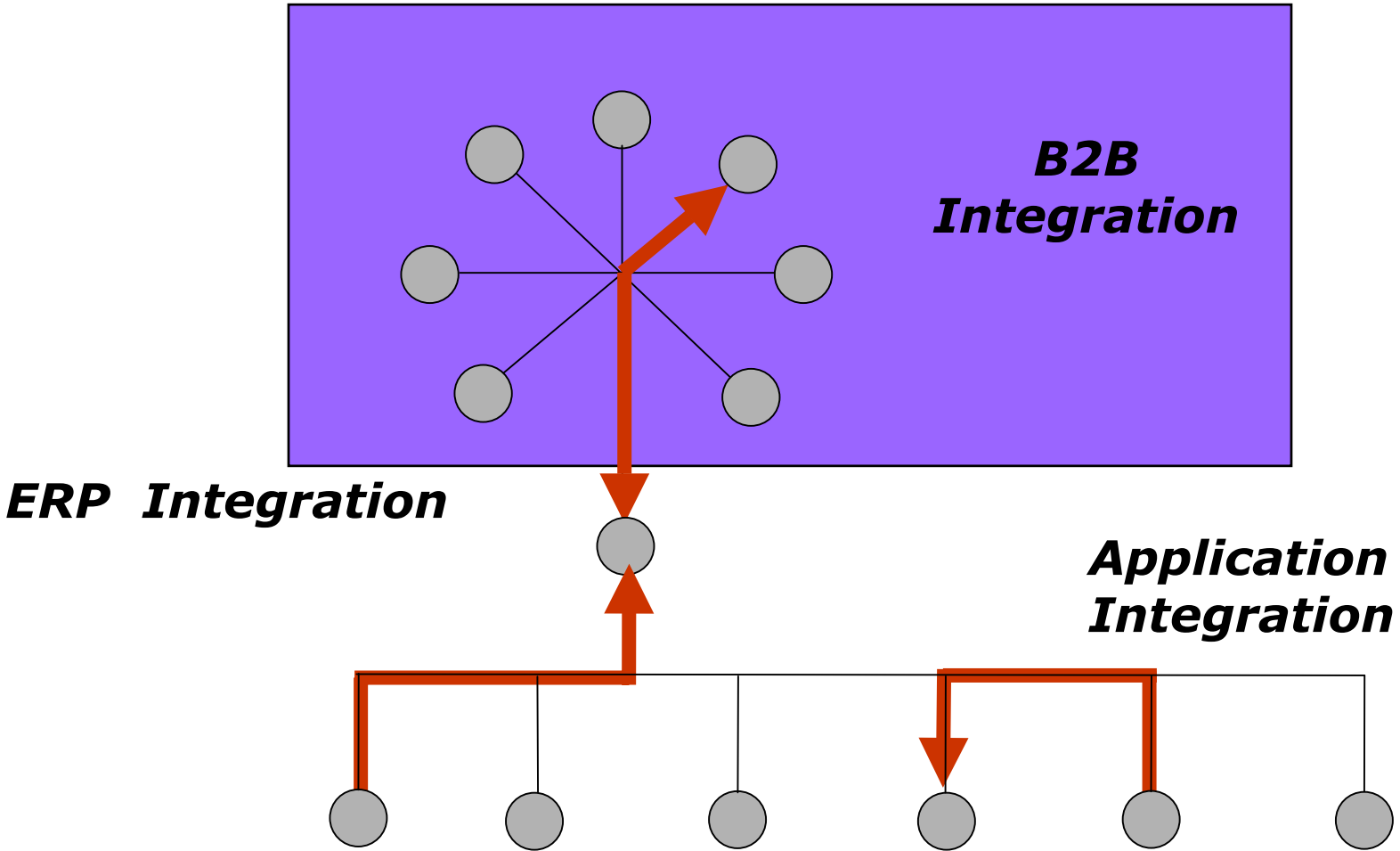

Step 2 : B2B Challenge

- **Any Trading Partner, Supplier or Marketplace.**
- **Integrate with ERP - SAP.**
- **Low & High Technology Customers / Suppliers.**
- **Open B2B with Cross-Vendor Technologies.**
- **Open XML, Industry Standards & Integration.**
 - **CIDX (ChemXML), RosettaNet, Custom**

III. Solutions Backbone

Collaboration Framework

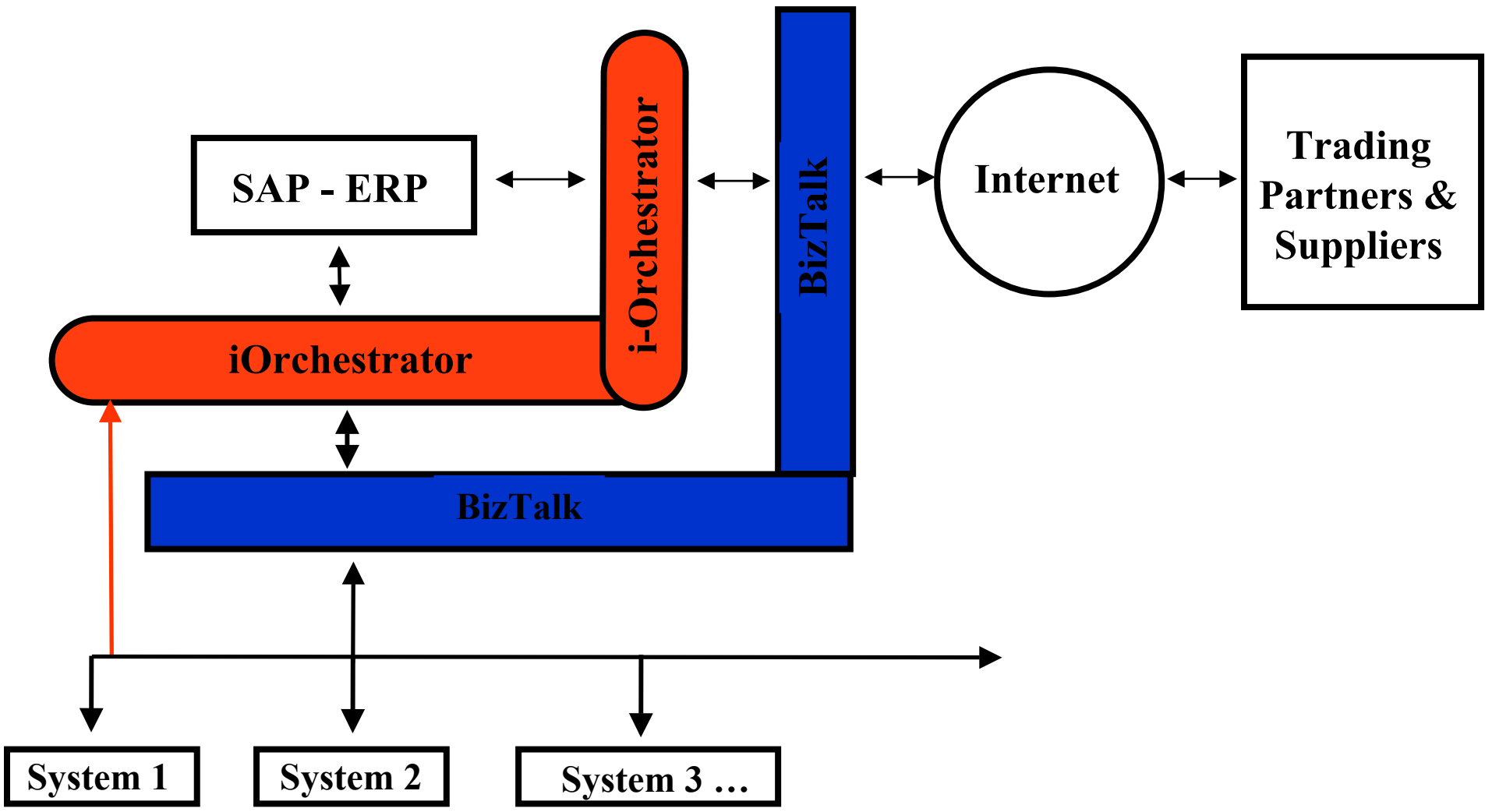

PO Collaboration - B2B

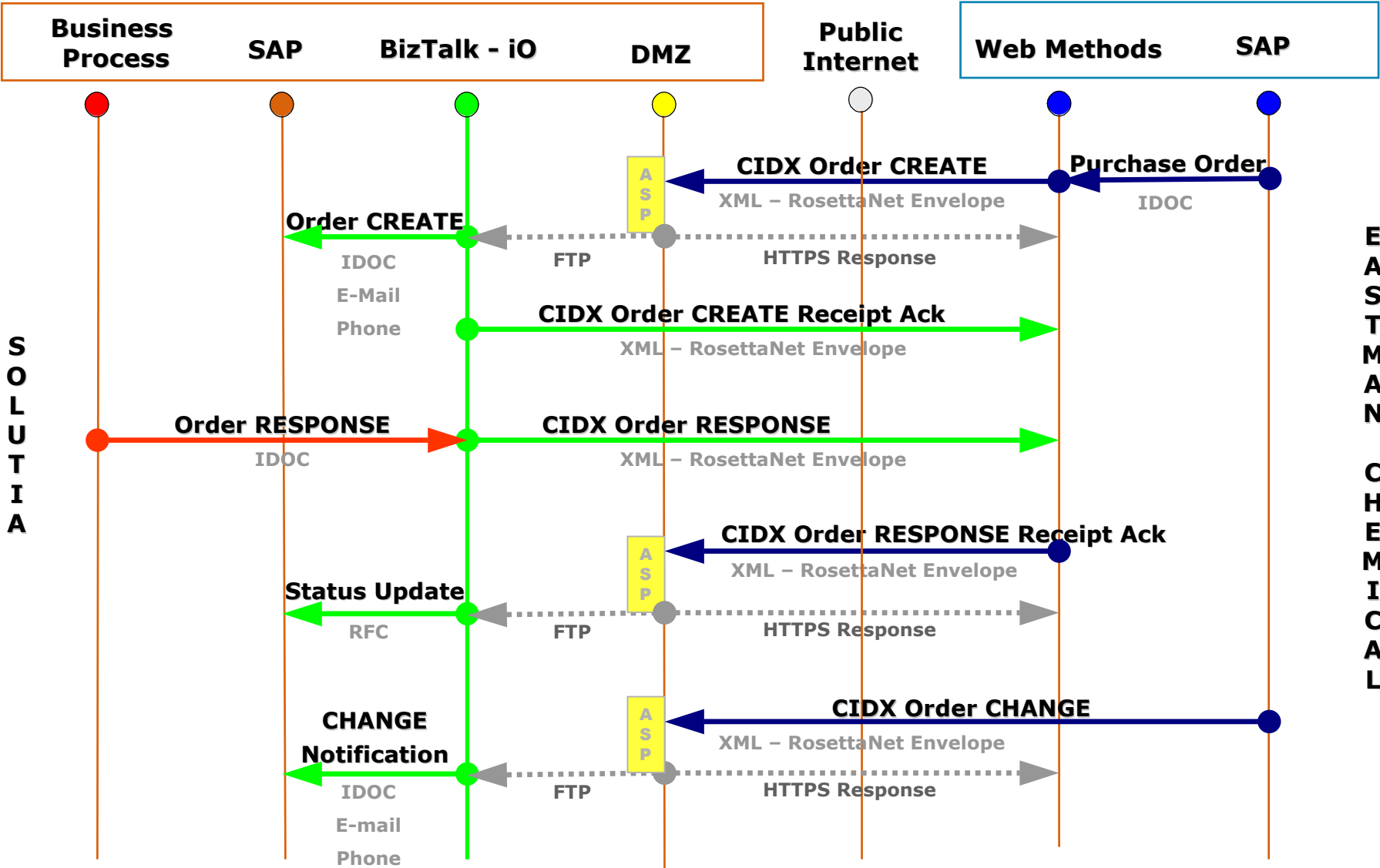

Product Quality – Certificates of Analysis ...Toll Manufacturing

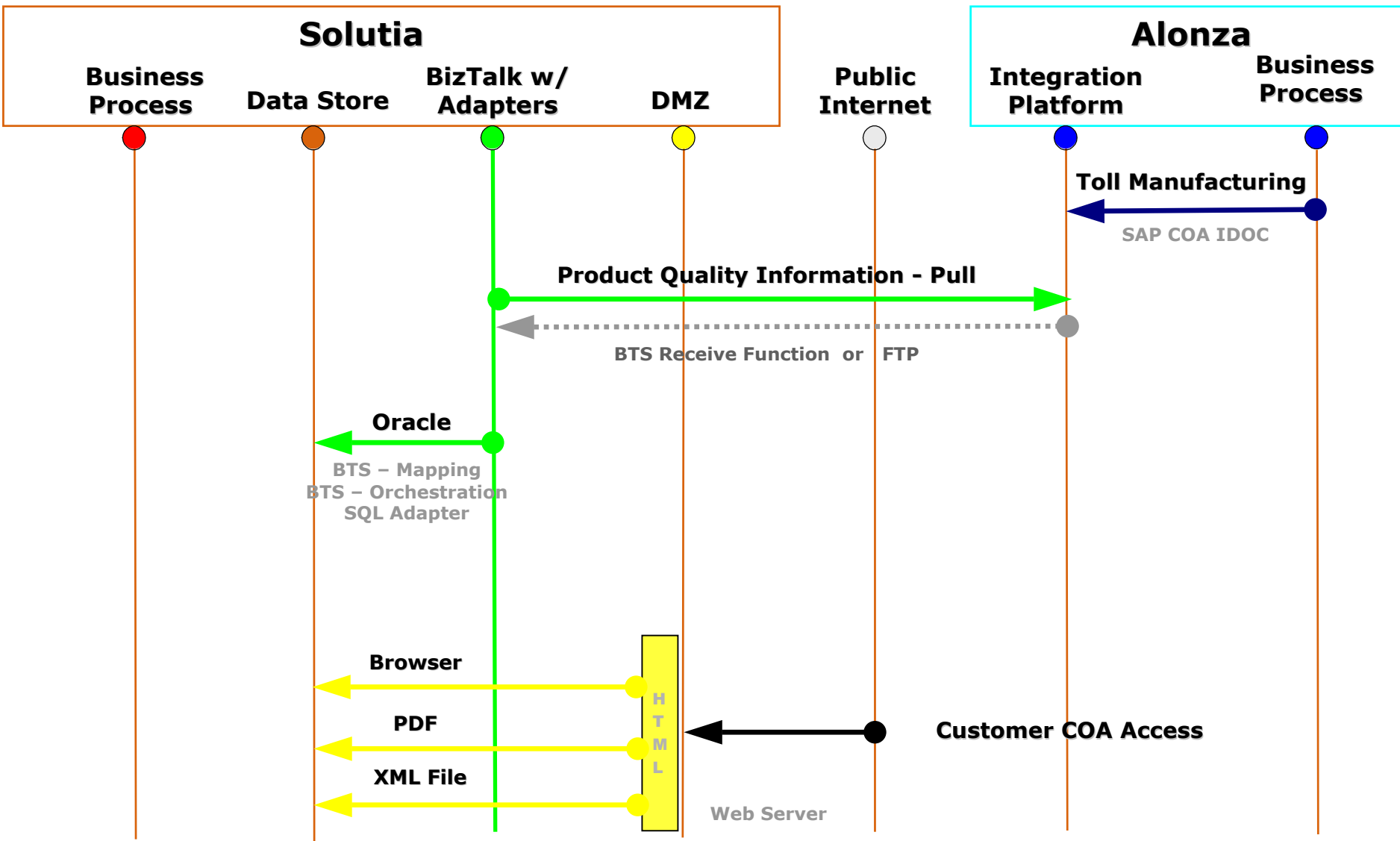

Invoice Collaboration

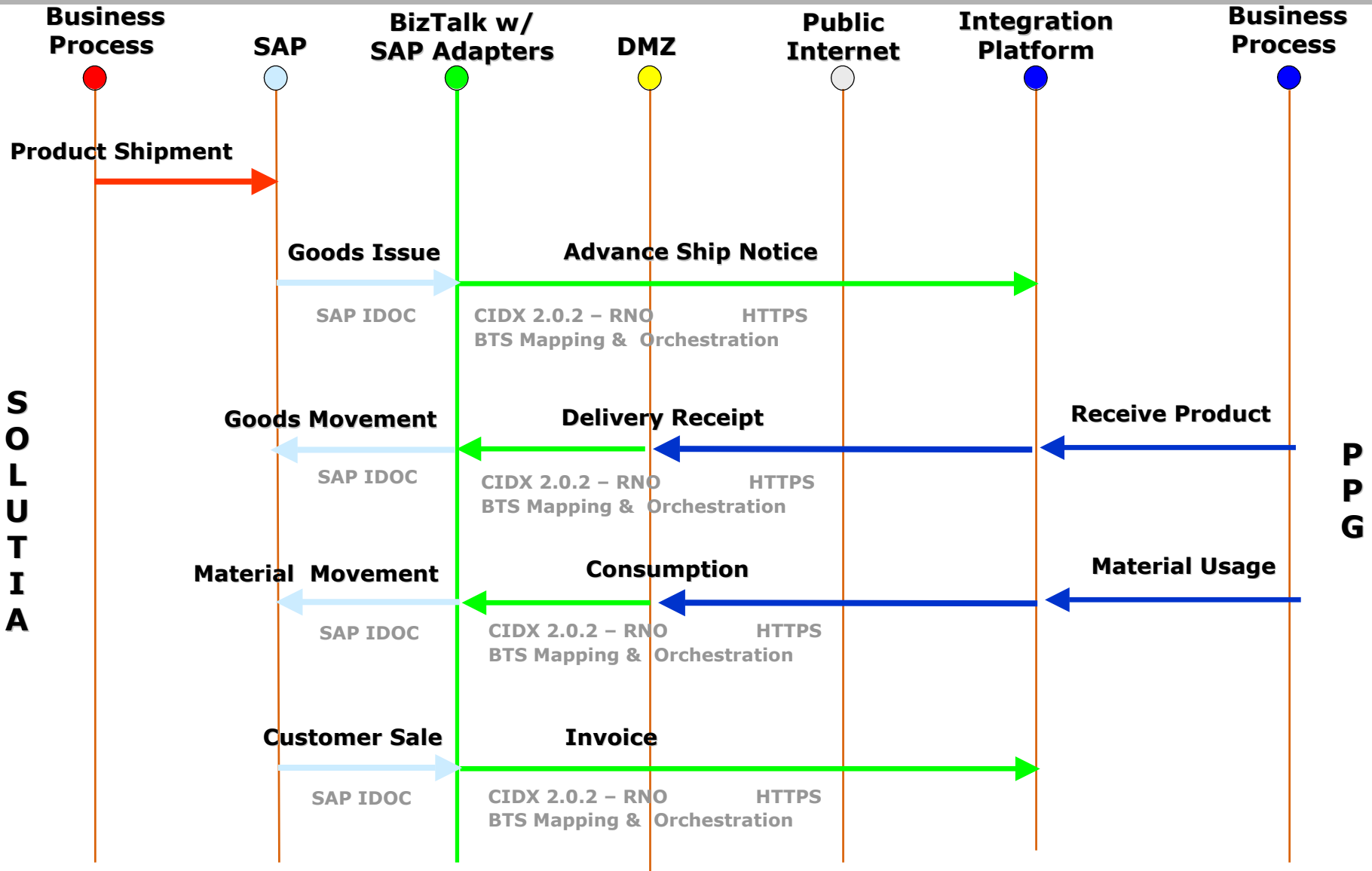

S
O
L
U
T
I
A

P
P
G

IV. Benefits & Value

Enterprise Collaboration Backbone

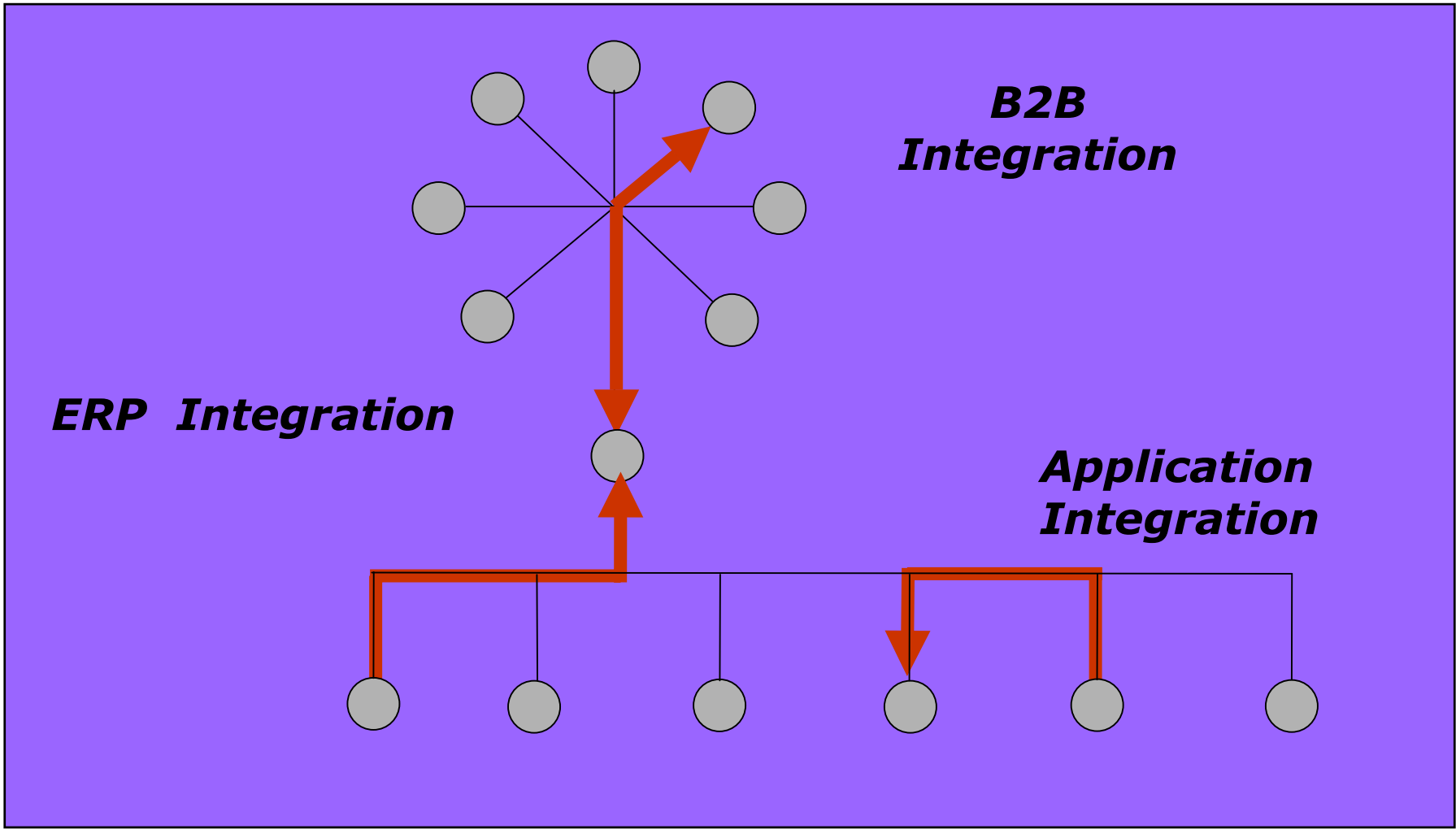

Collaborate Internally and to the World

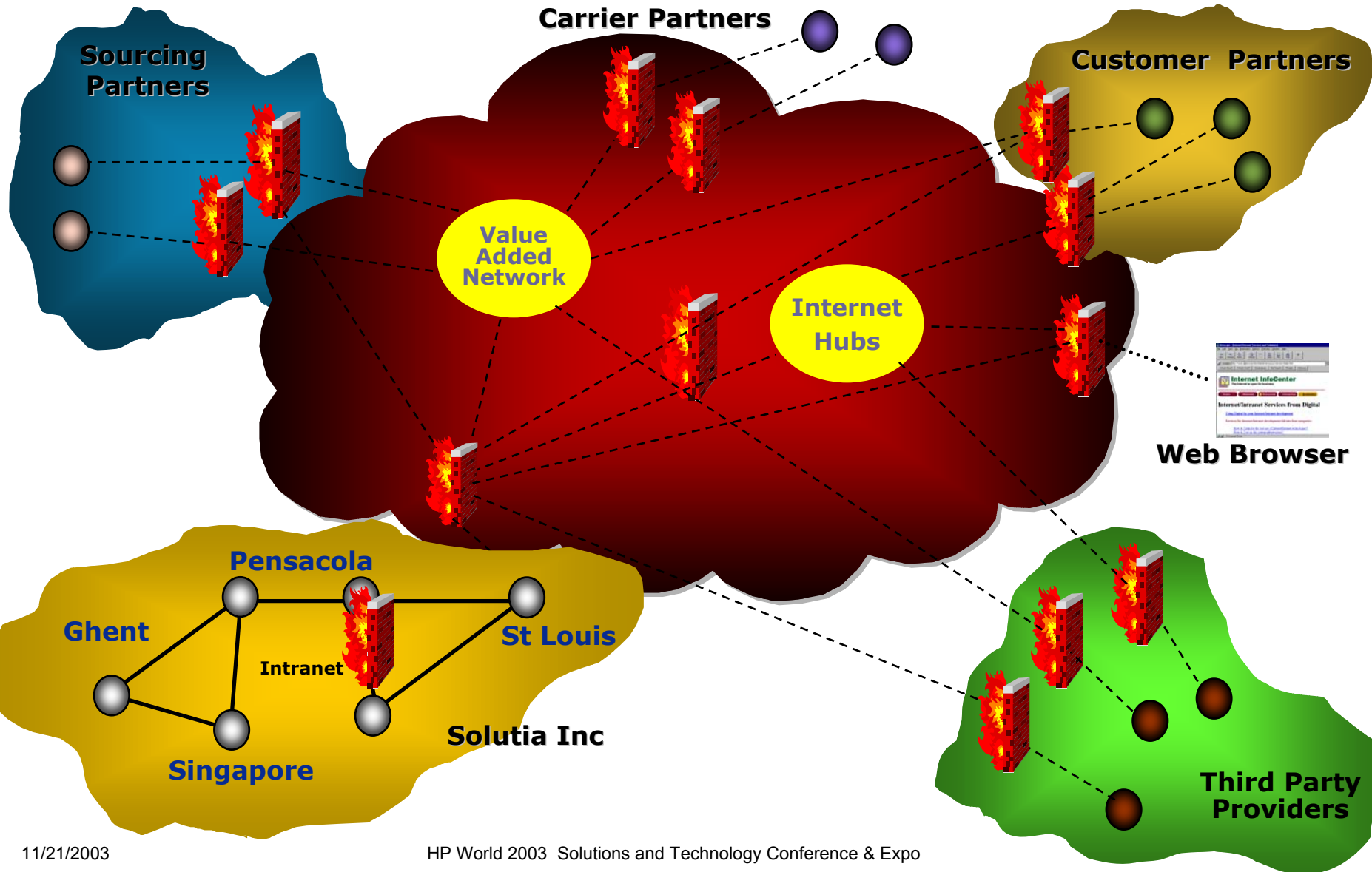

Benefits Summary

- **Increased customer service Closer to customer needs.**
- **Shortens business cycles Improves cash flow.**
- **Lower IT operational costs Hardware, software, resources.**
- **Increased ROI on business & technology projects.**
- **Earlier benefits delivery.**
- **Significantly reduced IT Costs on projects.**
- **Reduces maintenance & reoccurring support costs.**

- **Removes the “Integration Barriers & Walls” and opens the doors to business collaboration.....**

Benefits Summary

- **Repeatable Solutions :**
 - **Leverage Heritage :**
 - **Scaleable Deployment :**
 - **Investment:**
 - **Effort :**
 - **Flexibility :**
 - **Technology :**
 - **Non – invasive :**
 - **Mission Critical Connectivity :**
 - **e-Business Deployment :**
- Enterprise Standards**
Transform not Replacement
A2A , ERP , B2Bi , B2C
Lowest Cost Of Ownership
RAPID Deployment
Business and Technology
Partner With Industry Leaders
Configuration vs. programming
24x7 Uptime
Full XML Transformations

Benefit Realization

- **Capability related**
 - Agility/Speed in reacting to changes in business structure & dynamic information requirements.
 - Scale system supply chain capability by business area without losing enterprise continuity, analysis and reporting capability. For example, some businesses require MRP II Class A certification others do not.

- **Information Technology savings & improvements**
 - Total I.T. spending has been reduced by 41% since 2000 without significantly reducing user capability.
 - SAP operating and support cost have been reduced by 50% since 2000
 - Project costs savings of +\$10M to integrate manufacturing & distribution systems to SAP was realized
 - Project cost savings of \$2M have been realized related to SAP upgrades
 - Very low on-going integration support costs

- **Recently certified business benefits (certified for one business unit)**
 - On time delivery statistics improved from mid 80 percent to 95 percent
 - Inventory reductions of 22%
 - Supply chain related cost reductions of \$10M+ per year
 - Incremental capacity increases enabled launch of new products without having to spend capital to increase production capacity

V. Key Learnings

Collaboration is Components not Programming ...

Long Running Transactions **SSL** **DTD** **XML Schema**

Channels Ports **COM+** **XSLT** **xLang Port**

XML **CIO** **SMTP** **AIC**

Envelopes **HTTP** **SOAP** **MSMQ**

xLang Schedule **Adapters** **Hydration**

Functoids **Wrappers** **WebDAV**

ASP **DCOM**

BizTalk Framework **Messaging** **Receive Function** **Scripting Components**

Understand Value versus Effort

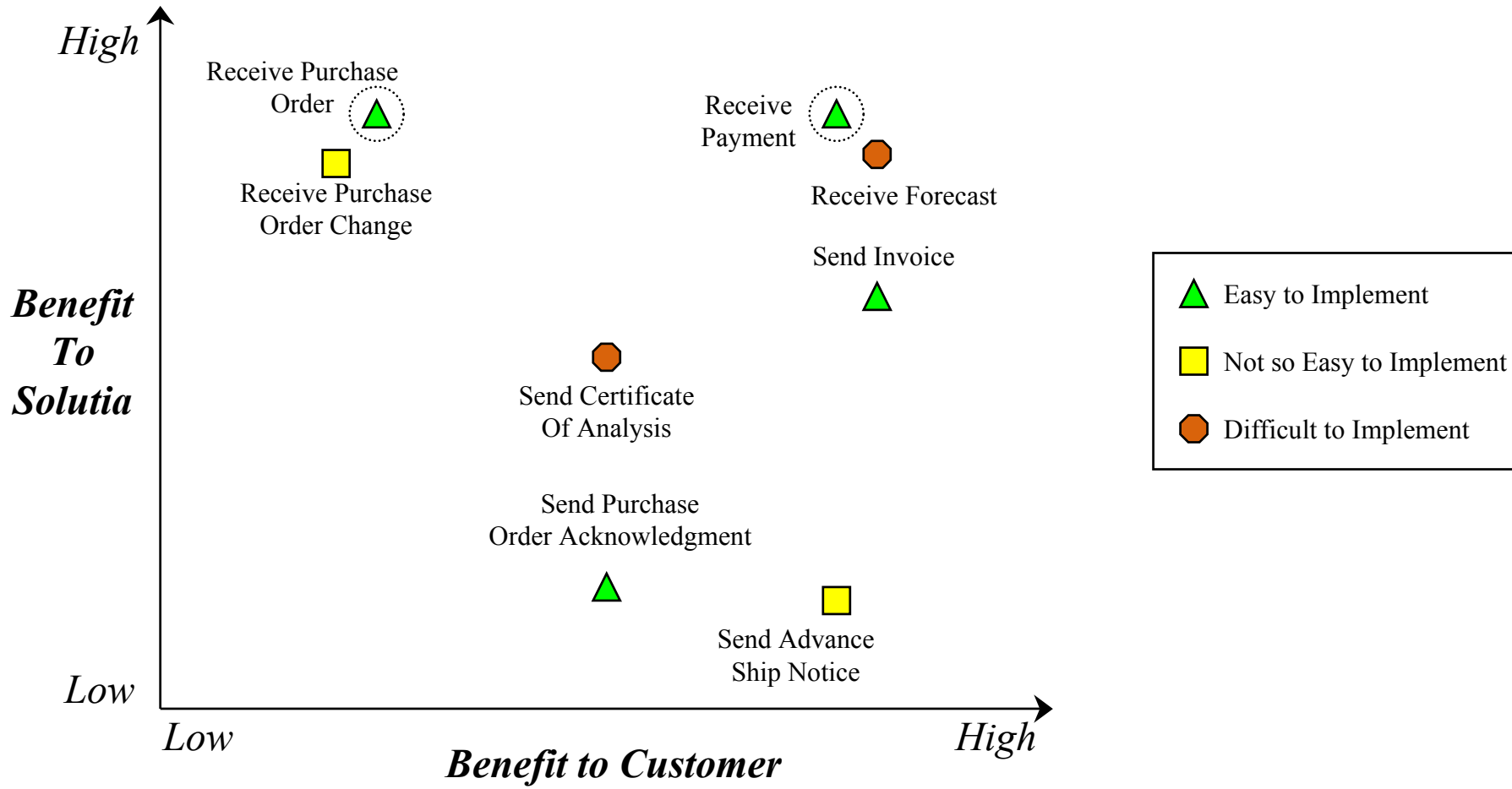

- **Collaboration solutions are available for deployment
.... Not “smoke & mirrors”**
- **Identify “pain – points”, put “Stake in the Ground
.... PROTOTYPE solutions.**
- **Establish “Collaboration Strategy & Framework”
..... With point-solution delivery.**
- **Tightly couple Integration & Collaboration Strategies
with Technology & vendor relationships**



HP WORLD 2003

Solutions and Technology Conference & Expo

Interex, Encompass and HP bring you a powerful new HP World.

